



# MACRO

# M10



THE GREATEST SMALL SWEEPER



Nowadays, the evolution of media control devices allows the design of highly adaptable and reliable systems. In the case of a road sweeper, thanks to these devices the various on-board devices can now be interfaced, to achieve unprecedented levels of user-friendliness and safety. And there is more: the development of such devices has reached a degree of almost total reliability.

This is why MACROCLEAN guarantees all on-board electronic devices for 5 years.

Many government nowadays are widely engaged in reducing pollution, M10 fits perfectly in this clean air policy.

The M10 is equipped with the lowest emission engines, however, the machine needs no AD BLUE to fulfil this requirement.

This feature makes M10 to be LOW EMISSION - LOW MAINTENECCE





# MACRO

The **GREAT** road sweepers

What makes our road sweeper really great? Comfort with attention to detail, advanced technology and the ability to offer performance beyond the standards in every respect: efficiency, safety and environmental compliance. All our machines are designed and built in Italy to respond effectively to the most special cleaning needs on large surfaces, in the industrial and urban areas. Discover the model that suits you and you will find the greatest partner for your work.



MACRO M10 is made for an important mission: clean cities comfortably. Designed for the well-being of the driver and for the urban image, MACRO M10 is convincing for its comfort, ease of use, safety and great manoeuvrability. Strong and powerful, is designed to face long work shifts without stress for the operator.

Automatic functions, cabin comfort, simple controls and its exclusive system to remove obstructions from the suction mouth, makes M10 the ideal tool for all round city cleaning: From pedestrian areas to arcades, from parking lots to squares.

The machine can be equipped with urban furniture maintenance systems and, last but not least, the one cubic meter volume container, compact but roomy makes it perfect for both city centres and large public areas

# M10

**MACROCLEAN IS A RCM BRAND, DISTRIBUTED WORLDWIDE.**

# ENHANCED DRIVER COMFORT AND SAFETY

The cabin of M10 is the state of the art for everything related to the well-being of people. Large and comfortable, it has been carefully insulated from outside temperature, noise, vibration and dust, in order to ease the long work shifts. In addition to the large room, another important aspect is given by the robust and intuitive controls: with a few simple moves you can make the most of the great cleaning performance of M10, without being distracted while driving.



## DIAGNOSTIC SYSTEMS

Electronics has undoubtedly made our lives easier in many ways, and MACRO M10 is no exception. The on-board diagnostic system ensures that any failure, even those not perceived by the operator, are promptly reported.

Thanks to a coding system, all you have to do is communicate to the service centre the code that appears on the display and the technicians will be ready to solve the problem.



## EASY START

To avoid distractions while driving, the controls of MACRO M10 are made of physical buttons that can be easily located and operated. To make the machine even easier to use, pressing the EASY START button automatically activates all the machine functions.

**M10**



# M10



## DUMPING HATCH

The waste hopper is designed for the easiest cleaning and sanitising. Utmost care has been taken to avoid creating blind spots where dirt can accumulate.

In addition, the opening cylinder keeps the hatch in horizontal position without the need for props, so that cleaning and inspection work can be carried out easily and away from dirt.



# TECHNOLOGY THAT IMPROVES EVERYONE'S WORK

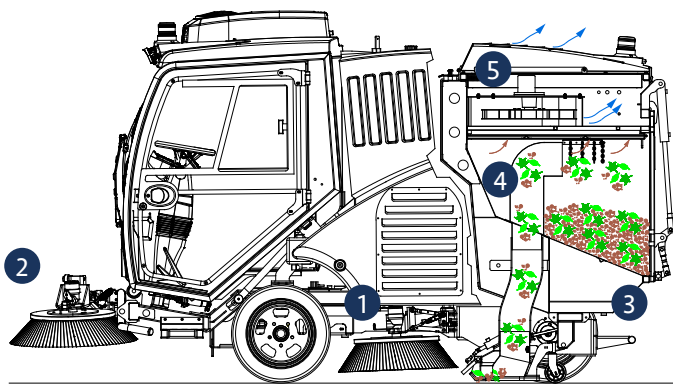

Debris are collected into the hopper by mean of suction without passing through the fan.

Side (1) and front (2, optional) brooms pushes the dirt towards the suction mouth (3). Thanks to the short length of the suction hose (4) the turbine (5) is extremely efficient Dust suppression by mean of water sprinkles on side brushes and inside the suction mouth

## NO LINES OF DIRT ON THE GROUND

The sweeping system of Macro M10 is designed to ensure ease of use, excellent performance and productivity. The geometry of the side brushes has been carefully studied in order to overlaps suction mouth width. Thanks to this feature you get a clean track free of dirt lines even when making very tight turns. The protection is ensured by a brush retraction system in case of impact.

## NO CLOGGING

Anyone who has used a sweeper knows how problematic can be a suction hose clogging. Those clanging can be sometimes can be very frequent, especially in leaf fall season.

For this reason the MACRO M10 is designed so that you can lift your mouth suction up to one meter from the ground. This allows a very easy blockages removal, without being forced to lie down under the machine.





# M10

## TECHNOLOGY THAT IMPROVES EVERYONE'S WORK



### HIGH DUMP

MACRO M10 is the only sweeper of its size with variable height dumping. The hopper can be emptied at any height between 500 and 1,500 mm. Hopper lift and door opening are separate functions, this helps to place the M10 next to the container when the hopper is still closed. Moreover, it allows to access the engine compartment with no need to dump the hopper.

### FRONT STEERING

Manoeuvrability is one of the key features for compact sweepers like M10. For this reason the machine is designed to be front wheel steering. This makes the sweeper very manoeuvrable and intuitive even to unexperienced users as it behaves exactly like a normal car. Front steering and short wheelbase makes difficult moves, reverse and narrow aisles a lot easier to handle.





## TILTING CABIN

The machine is completely hydraulic, so the periodic maintenance operations are few and simple. In addition to providing easy access to the engine for routine checks, the tilting cabin ensures a quick and effortless maintenance.

## MAXIMUM ACCESSIBILITY

Dirt accumulated in hidden spots can be a problem for a cleaning machine as can affect performance and safety. For this reason M10 is designed so that every part of the machine is easy to reach for cleaning, repair and maintenance.



## RADIATORS FAR FROM DIRT AND EASY TO CLEAN

When leaves or dust clog the radiators, they become a risk for the safety and reliability of the sweeper

In the MACRO M10 radiators are installed where will not get dirty during hopper dumping, far from dirt accumulations.

And most importantly, their position allows a very easy cleaning.





## MANUAL SUCTION HOSE

MACRO M10, can be equipped with a Rear manual suction hose 3m length, 110 mm diameter it is a very handy accessory to collect materials accumulated in hard to reach spots.

## THIRD FRONT BRUSH

The third front brush can be extended beyond the overall dimensions of the machine, widening the cleaning track and increasing the distance from parked cars, walls, guard-rails etc. reducing contact risk. The front brush is easily and intuitively controlled by a joystick on driver's seat armrest.



## HIGH-PRESSURE GUN

The large water tank can also feed a high-pressure gun system. The reel installed on the machine is equipped with a 15-meter pipe. Thanks to its central and rear position on the machine, the gun can be used on both sides. It is perfect for washing walls, pavements, urban furniture and for cleaning the machine itself.

## AIR CONDITIONER

Spend several hours a day driving can be exhausting for people. With this in mind MACRO M10 has been equipped with a robust and reliable air conditioning system, developed after Macroclean's experience in tropical climates.







MACRO  
M10

The GREAT road sweepers

MACROCLEAN.IT



# M10

## VACUUM ROAD SWEEPER 1 M<sup>3</sup>, STAGE V

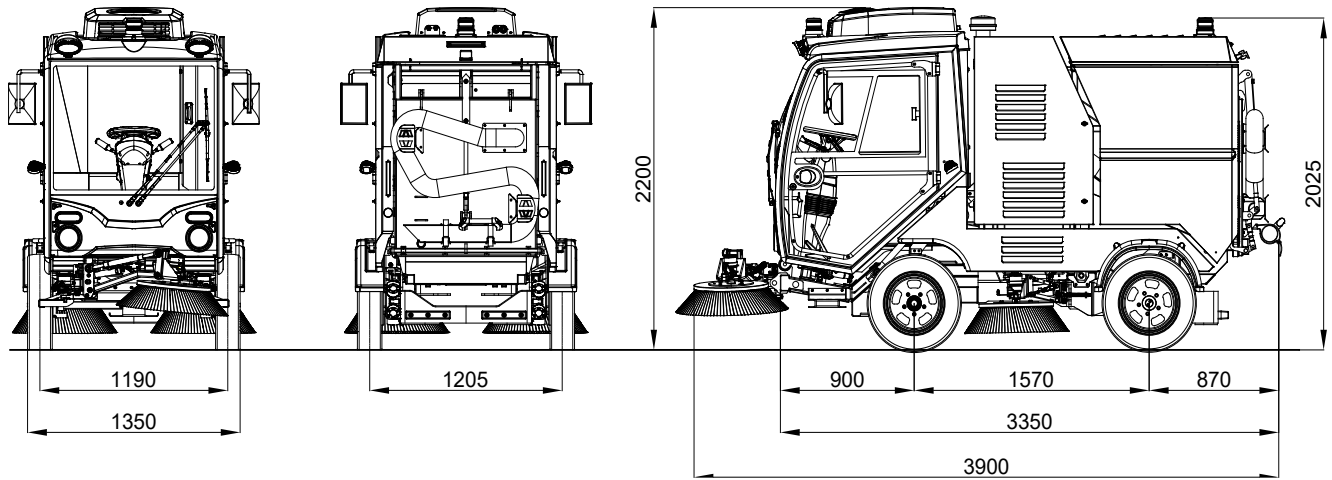

### VEHICLE CHARACTERISTICS

Engine	VM Stage V
Stage V version engine	55,4 kW / 74,3 Hp
Displacement / no. of cylinders	2228 cm <sup>3</sup> / 3
Fuel	Diesel
Cooling system	Fluid
Maximum speed	25 Km/h
Max. gradient	20%
Type approved seats	1
Driving position	Central
Brakes	Hydraulic Rear wheels drums
Parking brake	Mechanic Rear wheels drums
Steering	Hydraulic
Front suspension	Swinging front axle
Drive system	Hydraulic independent motors on each rear wheel
Kerb to kerb turning radius	4300 mm
Wheels steering	2, front axle
Tyres	185/65 R15
Lighting system	Led type road approved
Rotating beacons	Two LED stroboscopes
WEIGHTS	
Unladen weight	2410 Kg
Full load weight	2930 Kg
Load capacity	520 Kg

### CLEANING TRACK

Cleaning system	Vacuum
With right and left-hand side brush	1800 mm
With third front brush	2200 mm

### BRUSHES

Central brush	2, PPL / Steel
Third front brush	PPL / Steel
Adjustment of side brush pressure	Mechanic
Adjustment of central brush pressure	Mechanic

### WASTE HOPPER

Volume	1 m <sup>3</sup>
Dumping height	1500 mm
Hopper material	Stainless steel
Hopper door opening	Hydraulic at 90°

### WATERING SYSTEM (OPT)

Water tank capacity	300 L
Tank material	Stainless steel

### SUCTION SYSTEM AND DUST CONTROL

No. of turbines	1
Turbine type	Hydraulic
Dust filter	Stainless steel grid
Rear manual leaf vacuum hose (opt)	length 3m/Ø 110mm

**MACROCLEAN S.r.l.**

**Headquarters** Via Bonati 13, 29017 Fiorenzuola D'Arda - Piacenza - Italy  
**Registered office** Via Tiraboschi 4, 41043 Casinalbo - Modena - Italy  
 info@macroclean.it | [www.macroclean.it](http://www.macroclean.it)

A group RCM company

**MACRO**

The **GREAT** road sweepers